

Contents

1 Introduction	3
1.1 The Geberit Mapress pressfitting joint	3
2 Components	4
2.1 Geberit Mapress system components	4
2.2 Geberit Mapress Stainless Steel	4
2.2.1 Geberit Mapress Stainless Steel pressfittings	4
2.2.2 Geberit Mapress Stainless Steel system pipes	4
2.3 Geberit Mapress Carbon Steel	5
2.3.1 Geberit Mapress Carbon Steel pressfittings galvanised	5
2.3.2 Geberit Mapress Carbon Steel system pipes	5
2.4 Geberit Mapress pressing tools	5
3 Applications and planning guidelines	6
3.1 Installation in accordance with LPCB	6
3.2 System layout	9
3.3 Hazard classifications	9
3.4 Connections to mains water	9
3.5 Pipe supports	10
3.6 Calculation of pressure losses in pipework	10
3.6.1 Equivalent pipe lengths	11
3.7 Expansion compensation	15
3.7.1 Calculating expansion in Mapress Stainless Steel	16
3.7.2 Calculating expansion in Mapress Carbon Steel	20
3.8 Laying techniques	24
3.9 Wall penetrations	24
4 Installation	25
4.1 Tooling	25
4.2 Transport and storage	25
4.3 Making a Mapress press connection	25
4.4 Prepare the pipe and fitting for the pressing operation	26
5 Commissioning	30
5.1 Bending the system pipes	30
5.2 Connections	30
5.3 Flushing the pipes	30
5.4 Pressure and leak test	30
5.5 Refilling and air-bleeding of the pipe system for commissioning	30
5.6 Compatibility of additives	30
5.7 Compatible paints and coatings	31
5.8 Maintenance	31
5.9 Service life	31
6 Support services	32
6.1 Geberit technical service	32
6.2 Training	32

1 Introduction

Automatic sprinkler systems are designed for the purpose of detecting and suppressing or extinguishing a fire as early as possible during its initial phase so that it can be safely extinguished using other means. These suppression systems and components are subject to special requirements by the certifying bodies.

LPCB approved Geberit Mapress pipes and fittings intended for use in sprinkler systems in accordance with the LPC Rules for Automatic Sprinkler Installations are available with a nominal diameter of DN 20 to DN 100 in stainless steel and carbon steel (internally & externally galvanised).

With the Geberit Mapress pressfitting pipe and fittings system, pressing the fitting and pipe together produces a permanent and high-strength pipe joint. The permanent tightness of the connection is achieved by the seal rings that are inserted into the pressfitting bead by the manufacturer. The system has been used since 1969 in non-alloy steel for closed heating systems and since 1985 in stainless steel for drinking water systems. Since then the product range of Geberit Mapress pressfitting products for applications in the areas of building services and industry as well as in marine applications has been continuously expanded. Geberit Mapress has been widely used in sprinkler systems across Europe since 1984 and in 2011 has received LPCB approval.

Other Geberit Mapress products outside the range approved by LPCB and intended for use in the LPC rules for automatic sprinkler installations can be found in the Geberit Supply Systems Product Guide and includes Geberit Mapress CuNiFe, a seawater resistant copper-nickel alloy. For water extinguishing systems, pipes with a nominal diameter of DN 20 to DN 100 are available in stainless steel, carbon steel internally/externally galvanised and CuNiFe.

The Geberit Mapress pressfitting system is manufactured to meet the design and installation requirements of building fire protection.

These systems include the following components:

- Geberit Mapress pressfittings
- Geberit Mapress system pipes
- Geberit Mapress pressing tools.

1.1 The Geberit Mapress pressfitting joint

The pressfitting, with seal rings factory-fitted in the ends, is the basic element of the system. The Geberit Mapress system pipe is inserted into the pressfittings as far as the specified insertion distance. The joint is created using the Geberit Mapress pressing tool.

The pressing operation has an impact on two levels. Firstly, the mechanical strength of the connection is achieved. Secondly, the o-ring ensures the watertight seal of the connection.

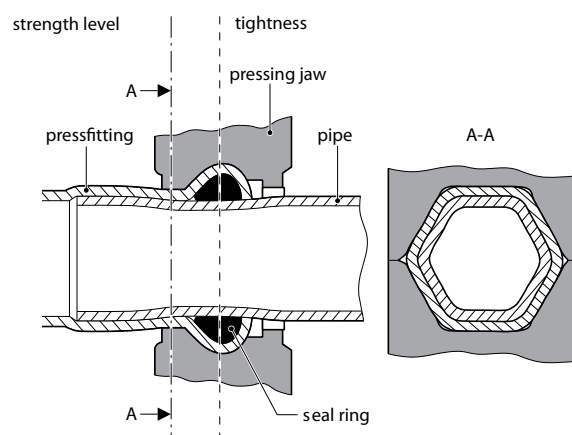

Figure 1: Section through a pressfitting joint with the pressing jaw (hexagonal pressing contour) still in position.

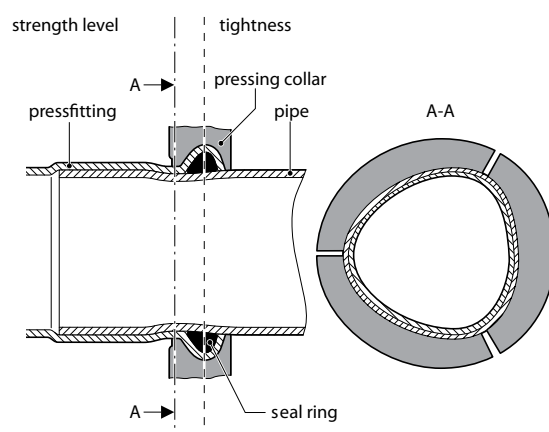

Figure 2: Section through a pressfitting joint with the pressing collar (lemon shaped pressing contour) still in position.

2 Components

2.1 Geberit Mapress system components

The individual components of the Mapress system are carefully matched. In fire protection systems, Geberit Mapress pressfittings may therefore only be used in conjunction with Geberit Mapress system pipes and pressing tools. Sizes, weights and package units can be found in the Geberit product catalogue.

The fitting ends are provided with a pressing indicator in the factory. The pressing indicator is destroyed by the pressing procedure and shall subsequently be manually removed by the installer after pressing.

The pressing indicator has the following functions:

- Indicates to the installer, before the pressure test, that there are unpressed connections
- Displays the dimensions of the fittings in an unpressed state
- Clearly identifies the fitting as a Geberit product in an unpressed state
- Indicates the material of the fitting by its colour - blue for stainless steel and red for carbon steel in an unpressed state.

All Mapress fittings also come with a protection plug on each end. This protects the seal ring from dust and dirt, increasing hygiene and safety.

2.2 Geberit Mapress Stainless Steel

The Geberit Mapress Stainless Steel pressfitting system is LPCB approved for use in wet sprinkler systems to the LPC Rules for Automatic Sprinkler Installations. The system can be installed directly in concrete.

Geberit Mapress Stainless Steel is listed under the Water Regulations Advisory Scheme for use in drinking water installations. Certificate No: 0610086.

2.2.1 Geberit Mapress Stainless Steel pressfittings

Geberit Mapress Stainless Steel pressfittings, also free of silicone, are made of high-alloyed 316 steel, X5CrNiMo17-12-2 in accordance with DIN EN 10088, material no. 1.4401/AISI 316. All fittings are solution and bright annealed to increase corrosion resistance. The stainless steel press connectors leak if unpressed and are marked with the manufacturer code as well as with the LPCB certification marks (on the packaging label).

2.2.2 Geberit Mapress Stainless Steel system pipes

Geberit Mapress Stainless Steel system pipes are made of the same high quality 316 steel as the pressfittings. A factory standard ensures that additional increased requirements are met:

- Increased molybdenum content, at least 2.2 %
- Weld seam additionally smoothed on the inside, solution and bright annealed for increased corrosion protection
- Pipe length 6 m
- Can be cold bent (see section 5.1).

They bear the LPCB, FM, TUV and DVGW certification marks. The thin-walled pipes and pressfittings lead to a weight reduction of about 50% compared to conventional standard pipework.

Table 1: Pipe dimensions in stainless steel

DN	Size (mm)	
	Ø x s (mm)	Weight (kg/m)
20	22.0 x 1.2	0.626
25	28.0 x 1.2	0.806
32	35.0 x 1.2	1.260
40	42.0 x 1.5	1.523
50	54.0 x 1.5	1.974
65	76.1 x 2.0	3.715
80	89.9 x 2.0	4.357
100	108.0 x 2.0	5.315

Ø = outside diameter

s = wall thickness

2.3 Geberit Mapress Carbon Steel

The Geberit Mapress pressfitting system made of carbon steel, is LPCB approved for use in wet sprinkler systems to the LPC Rules for Automatic Sprinkler Installations.

2.3.1 Geberit Mapress Carbon Steel pressfittings, galvanised

The Geberit Mapress Carbon Steel pressfittings are made of non-alloy steel, material no. 1.0034, in accordance with DIN EN 10305. They are galvanically zinc-plated with a protective layer (Fe/Zn 8B, blue chromated) that is at least 8 µm thick. Furthermore, Geberit Mapress Carbon Steel pressfittings leak if unpressed and are marked with a red pressing indicator. They bear the manufacturer code as well as the LPCB, VdS and FM Certification marks (on the packaging label).

2.3.2 Geberit Mapress Carbon Steel system pipes internally/externally galvanised

The Geberit Mapress system pipe made of non-alloy steel, material no. 1.0215, is a thin-walled, welded and internally/externally galvanised precision steel pipe that also meets the requirements of the Geberit Mapress factory standard concerning dimensional accuracy and surface quality. These pipes are manufactured from metal strips galvanised on both sides.

The thickness of the zinc layer on the internal as well as the external surface is 15–27 µm [zinc 275 g/m²].

The applied zinc plating process produces a smooth, high-density zinc layer, free of microscopic gaps and cavities for even better anti-corrosion properties.

The welding seam on the outside of the pipe is subsequently galvanised. The pipes are marked, among other things, with the manufacturer code as well as with the LPCB, FM and VdS Certification marks (on the packaging label). The thin-walled pipes and pressfittings lead to a weight reduction of about 50 % compared to conventional standard pipework.

Table 2: Pipe dimensions in non-alloy steel, internally/externally galvanised

DN	Size (mm)	
	Ø x s (mm)	Weight (kg/m)
20	22.0 x 1.2	0.758
25	28.0 x 1.2	0.980
32	35.0 x 1.2	1.239
40	42.0 x 1.5	1.498
50	54.0 x 1.5	1.942
65	76.1 x 2.0	3.655
80	89.9 x 2.0	4.286
100	108.0 x 2.0	5.228

Ø = outside diameter

s = wall thickness

2.4 Geberit Mapress pressing tools

Depending on the diameter and working pressure of the installation, the Geberit Mapress pipe joints are made using different Geberit Mapress pressing tools (see table 3 for more details).

3 Applications and planning guidelines

These installation instructions apply to Geberit Mapress pressfitting systems made of stainless steel and non-alloy steel galvanised in accordance with LPC Rules for Automatic Sprinkler Installations incorporating BS EN 12845.

For details regarding the installation of Geberit Mapress for sprinkler systems in accordance to VdS and FM approval, please contact Geberit directly.

To assist you with the planning, you can download CAD data for the pressfittings in dxf or dwg format from the Service section of the Geberit homepage.

3.1 Installation in accordance with LPCB

Geberit Mapress Stainless Steel pressfittings and system pipes are LPCB approved for use in accordance with the LPC Rules for Automatic Sprinkler Installations.

The approval covers wet systems at operating pressures up to either 12 or 16 bar, depending on the dimensions and pressfitting tool used (see Table 3) in conjunction with the black butyl rubber seal ring (CIIR).

Geberit Mapress Carbon Steel pressfittings with the standard black butyl rubber seal ring (CIIR) in conjunction with the internally/ externally galvanised system pipe are LPCB approved for use in accordance with the LPC Rules for Automatic Sprinkler Installations in wet systems with pressures 12 to 16 bar, depending on the dimensions and pressfitting tool used (see Table 3). For a full list of LPCB approved Geberit products, please refer to www.redbooklive.com or see Tables 4 - 5.

Table 3: Installation in accordance with LPCB approval

	Working Pressure (bar)			
	12		16	
Ø (mm)				
Tool	HCPS	ECO 301	HCPS	ECO 301
22		XY		XY
28		XY		XY
35*		XY		XY
42		XY		XY
54		XY		XY
76.1	XY	XY	X	
88.9	XY	XY	X	
108	XY			

X = stainless steel Y = carbon steel

* 35mm pressing collar to be used article no:90538

Table 4: LPCB approved Geberit Mapress Stainless Steel Sprinkler Pipework System Components

Description	Size/mm
Pipe	22, 28, 35, 42, 54, 76.1, 88.9, 108
Coupling	22, 28, 35, 42, 54, 76.1, 88.9, 108
Slip Coupling	22, 28, 35, 42, 54, 76.1, 88.9, 108
Bend 90°	22, 28, 35, 42, 54, 76.1, 88.9, 108
Bend 90° with plain end	22, 28, 35, 42, 54, 76.1, 88.9, 108
Bend 45°	22, 28, 35, 42, 54, 76.1, 88.9, 108
Bend 45° with plain end	22, 28, 35, 42, 54, 76.1, 88.9, 108
Reducer with plain end	28x22, 35x22, 35x28, 42x28, 42x35, 54x35, 54x42, 76.1x54, 88.9x54
	88.9x76.1, 108x76.1, 108x88.9
T-piece equal	22, 28, 35, 42, 54, 76.1, 88.9, 108

Table 4: Continued

Description	Size/mm
T-piece reduced	28x22x28, 35x22x35, 35x28x35, 42x22x42
	42x28x42, 42x35x42, 54x22x54, 54x28x54
	54x35x54, 54x42x54, 76.1x22x76.1, 76.1x28x76.1
	76.1x35x76.1, 76.1x42x76.1, 76.1x54x76.1, 88.9x22x88.9
	88.9x28x88.9, 88.9x35x88.9, 88.9x42x88.9, 88.9x54x88.9
	88.9x76.1x88.9, 108x22x108, 108x28x108, 108x35x108
	108x42x108, 108x54x108, 108x76.1x108, 108x88.9x108
T-piece with female thread	22x1/2"x22, 22x3/4"x22, 28x1/2"x28, 28x3/4"x28,
	28x1"x28, 35x1/2"x35, 35x3/4"x35, 42x1/2"x42
	42x3/4"x42, 54x1/2"x54, 54x3/4"x54, 54x2"x54
	76.1x3/4"x76.1, 76.1x2"x76.1, 88.9x3/4"x88.9, 88.9x2"x88.9
	108x3/4"x108, 108x2"x108
Adaptor with male thread	22x1/2", 22x3/4", 22x1", 28x3/4", 28x1", 28x1 1/4",
	35x1", 35x1 1/4", 35x1 1/2", 42x1 1/4", 42x1 1/2"
	54x1 1/2", 54x2", 76.1x2 1/2", 88.9x3"
Adaptor with female thread	22x1/2", 22x3/4", 22x1", 28x1/2", 28x3/4", 28x1"
	28x1 1/4", 35x1"
	35x1 1/4", 35x1 1/2", 42x1 1/4",
	42x1 1/2"
	54x1 1/2", 54x2"
Adaptor with brass union nut	22x1", 22x1 1/4", 22x1 1/2", 28x1", 28x1 1/4"
	28x1 1/2", 35x1 1/2", 42x1 3/4", 54x2 3/8", 76.1x3", 88.9x3 1/2"
Adaptor with stainless steel union nut	22x1", 28x1 1/2"
Adaptor union with male thread, nut made of stainless steel	22x1/2", 22x3/4", 22x1", 28x1/2", 28x3/4", 28x1"
	35x1 1/4", 42x1 1/2", 54x2"
Adaptor union with male thread, nut made of brass	22x1/2", 22x3/4", 22x1", 28x1", 35x1 1/4", 42x1 1/2"
	54x2"
Adaptor union with female thread, nut made of brass	22x3/4", 22x1", 28x1", 35x1 1/4", 42x1 1/2", 54x2"
Adaptor union with female thread, nut made of stainless steel	22x3/4", 22x1", 28x1", 35x1 1/4", 42x1 1/2", 54x2"
Elbow adaptor 90° with male thread	22x3/4", 28x1", 35x1 1/4", 42x1 1/2", 54x2"
Elbow adaptor 90° with female thread	22x3/4", 28x1", 35x1 1/4"
Straight union with press fittings on both ends	22, 28, 35, 42, 54
Flange PN 10 / 16 with pressing socket	22, 28, 35, 42, 54, 76.1, 88.9, 108
Cap	22, 28, 35, 42, 54

LPCB approval listing notes

1. The above Geberit Press-fit pipework and fittings are to be installed using the ECO301 and HCPS pressing tools only, in accordance with the Geberit Installation Instructions. These tools shall be serviced and maintained in accordance with manufacturers' stated guidelines.
2. Geberit Press-fit pipework and fittings may only be installed by LPCB approved or registered contractors who have undergone adequate training by the manufacturer.
3. Geberit Press-fit pipework and fittings shall be installed in accordance with the Geberit Installation Instructions, Issue 1. July 2011
4. Geberit Press-fit pipework and fittings shall be installed and maintained in conformance with the LPC Rules for Automatic Sprinkler Installations.
5. The use of Geberit Press-fit pipework and fittings shall be recorded on LPS1048 certificates of conformity.
6. Where a Geberit Reducer is installed, a pipe hanger shall be used adjacent to the reducer on the larger pipe.
7. Where Geberit system pipework is connected to sprinklers in suspended ceilings using flexible drops, only LPCB Approved flexible drops shall be used.
8. Geberit Press-fit pipework and fittings are not compatible with lightweight piping systems from other manufacturers.

Sprinkler Systems Installation Guide

Applications and planning guidelines

**Table 5: LPCB approved Geberit Mapress Carbon Steel internally/externally galvanised
Sprinkler Pipework System Components**

Description	Size/mm
Pipe	22, 28, 35, 42, 54, 76.1, 88.9, 108
Coupling	22, 28, 35, 42, 54, 76.1, 88.9, 108
Slip Coupling	22, 28, 35, 42, 54, 76.1, 88.9, 108
Bend 90°	22, 28, 35, 42, 54, 76.1, 88.9, 108
Bend 90° with plain end	22, 28, 35, 42, 54, 76.1, 88.9, 108
Bend 45°	22, 28, 35, 42, 54, 76.1, 88.9, 108
Bend 45° with plain end	22, 28, 35, 42, 54, 76.1, 88.9, 108
Reducer with plain end	28x22, 35x22, 35x28, 42x28, 42x35, 54x35, 54x42, 76.1x54, 88.9x54 88.9x76.1, 108x76.1, 108x88.9
T-piece equal	22, 28, 35, 42, 54, 76.1, 88.9, 108
T-piece reduced	28x22x28, 35x22x35, 35x28x35, 42x22x42 42x28x42, 42x35x42, 54x22x54, 54x28x54 54x35x54, 54x42x54, 76.1x22x76.1, 76.1x28x76.1 76.1x35x76.1, 76.1x42x76.1, 76.1x54x76.1, 88.9x22x88.9 88.9x28x88.9, 88.9x35x88.9, 88.9x42x88.9, 88.9x54x88.9 88.9x76.1x88.9, 108x22x108, 108x28x108, 108x35x108 108x42x108, 108x54x108, 108x76.1x108, 108x88.9x108
T-piece with female thread	22x1/2"x22, 22x3/4"x22, 28x1/2"x28, 28x3/4"x28, 28x1"x28, 35x1/2"x35, 35x3/4"x35, 42x1/2"x42 42x3/4"x42, 54x1/2"x54, 54x3/4"x54, 54x2"x54 76.1x3/4"x76.1, 76.1x2"x76.1, 88.9x3/4"x88.9, 88.9x2"x88.9 108x3/4"x108, 108x2"x108
Adaptor with male thread	22x1/2", 22x3/4", 22x1", 28x3/4", 28x1", 28x1 1/4", 35x1", 35x1 1/4", 35x1 1/2", 42x 1 1/4", 42x1 1/2" 54x1 1/2", 54x2", 76.1x2 1/2", 88.9x3"
Adaptor with female thread	22x3/4", 28x1/2", 28x1"
Adaptor with plain and welding end	15, 18, 22, 28, 35, 42, 54
Adaptor for groove systems	54
Adaptor with brass union nut	22x1", 22x 1 1/4", 22x 1 1/2", 28x1", 28x1 1/4" 28x1 1/2", 35x1 1/2", 35x2", 42x1 1/4", 42x2", 42x 2 1/4", 42x 2 3/8", 42x 2 1/2", 54x 2 1/2", 54x 2 3/4"
Adaptor union with male thread	22x3/4", 28x1", 35x1 1/4", 42x1 1/2" 54x2"
Adaptor union with female thread, nut made of stainless steel	22x3/4", 22x1", 28x1", 35x1 1/4", 42x1 1/2", 54x2"
Elbow adaptor 90° with male thread	22x3/4"
Elbow adaptor 90° with female thread	28x1/2"
Bend adaptor 90° with female thread	22x3/4", 28x1/2"

Table 5:
Continued

Description	Size/mm
Straight union with press fittings on both ends	22, 28, 35, 42, 54
Flange PN 10 / 16 with pressing socket	76.1, 88.9, 108
Cap	22, 28, 35, 42, 54

LPCB approval listing notes

1. The above Geberit Press-fit pipework and fittings are to be installed using the ECO301 and HCPS pressing tools only, in accordance with the Geberit Installation Instructions. These tools shall be serviced and maintained in accordance with manufacturers' stated guidelines.
2. Geberit Press-fit pipework and fittings may only be installed by LPCB approved or registered contractors who have undergone adequate training by the manufacturer.
3. Geberit Press-fit pipework and fittings shall be installed in accordance with the Geberit Installation Instructions, Issue 1. July 2011
4. Geberit Press-fit pipework and fittings shall be installed and maintained in conformance with the LPC Rules for Automatic Sprinkler Installations.
5. The use of Geberit Press-fit pipework and fittings shall be recorded on LPS1048 certificates of conformity.
6. Where a Geberit Reducer is installed, a pipe hanger shall be used adjacent to the reducer on the larger pipe.
7. Where Geberit system pipework is connected to sprinklers in suspended ceilings using flexible drops, only LPCB Approved flexible drops shall be used.
8. Geberit Press-fit pipework and fittings are not compatible with lightweight piping systems from other manufacturers.

3.2 System layout

Geberit Mapress is suitable for use in each element of an automatic sprinkler system. See Figure 3.

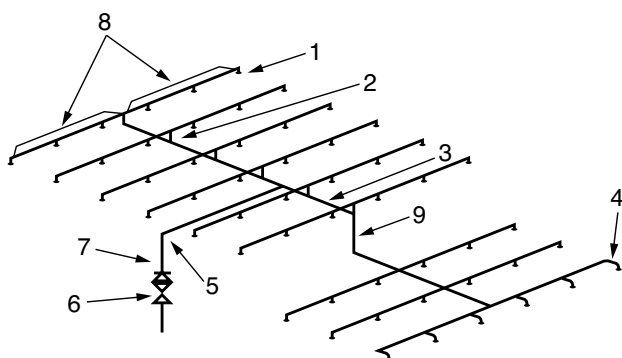

Figure 3: main elements of a sprinkler system

Key

- 1 Sprinkler head
- 2 Riser
- 3 Distribution pipe spur
- 4 Arm pipe
- 5 Main distribution pipe
- 6 Control valve set
- 7 Riser
- 8 Range pipes
- 9 Drop

3.3 Hazard classifications

Geberit Mapress is approved for use in hazard classification up to and including OH3 as defined in LPC rules for automatic sprinkler installations and in accordance with the LPCB approval.

3.4 Connections to mains water

Geberit Mapress Stainless Steel holds WRAS approval and therefore can be connected to water supply.

Geberit Mapress Carbon Steel is not WRAS approved. When using non-WRAS approved components in systems connected to town main water supplies, WRAS approved backflow preventers must be used.

3.5 Pipe supports

Pipe supports must be fixed directly to the building or, if necessary, to machines, storage racks or other structures. They must not be used to support any other installations. They must be of the adjustable type in order to secure an even load-bearing capability. Supports must completely surround the pipe and should not be welded to the pipe or fittings.

Distribution pipes and risers must have a suitable number of fixed points to take account of axial forces.

No part of any support must be made of combustible material. Nails must not be used.

No special pipe support brackets are required for the Geberit Mapress pressfitting system. Any appropriately sized commercially available brackets can be used. For maximum Geberit Mapress bracket spacing distances, see Table 6.

Table 6: Bracket distances in accordance with LPCB approval

DN	Pipe dimension Ø x s (mm)	Bracket distance (m)
20	22 x 1.2	2.5
25	28 x 1.2	2.5
32	35 x 1.5	2.5
40	42 x 1.5	3
50	54 x 1.5	3
65	76.1 x 2.0	3
80	88.9 x 2.0	3
100	108 x 2.0	3.5

The distance from any terminal sprinkler to a support shall not exceed:

- 0.9m for DN 25 diameter piping
- 1.2m for piping exceeding DN 25 diameter.

The distance for any upright sprinkler to a support shall not be less than 0.15m.

Vertical pipes shall have additional supports in the following cases:

- Pipes more than 2m long
- Pipes more than 1m long feeding single sprinklers.

3.6 Calculation of pressure losses in pipework

Frictional pressure loss in pipes shall be fully hydraulically calculated. The Hazen-Williams formula should be used:

$$p = \frac{6.05 \times 10^5}{C^{1.85} \times d^{4.87}} L Q^{1.85}$$

Where:







- p - is the pressure loss in the pipe, in bar;
- Q - is the flow through the pipe, in litres per minute;
- d - is the mean internal diameter of the pipe, in millimetres;
- C - is a constant for the type and condition of the pipe;
- L - is the equivalent length of pipe and fittings, in metres.

The values of C to be used in sprinkler installation for Geberit Mapress are:

- Stainless Steel - 140
- Carbon Steel - 120

3.6.1 Equivalent pipe lengths

Table 7: Equivalent pipe length – Mapress Ø 12 - 22mm

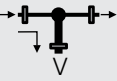
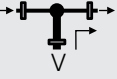
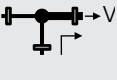
Designation	Pressfitting	Loss Coefficient	Dimensions Ø x s (mm)			
			12 x 1.0	15 x 1.0	18 x 1.0	22 x 1.0
Bend 90°		0.7	0.267	0.370	0.479	0.630
Elbow adaptor 90°		1.5	0.572	0.793	1.026	1.351
Pipe bridge		0.5	0.191	0.264	0.342	0.450
Bend 45°		0.5	0.191	0.264	0.342	0.450
Reducer		0.2	—	0.106	0.137	0.180
Sleeve/Adaptor		0.1	0.038	0.053	0.068	0.090
T-piece (flow separation)		1.3	0.496	0.688	0.889	1.171
T-piece (flow integration)		0.9	0.343	0.476	0.616	0.811
T-piece (through-flow)		0.3	0.114	0.159	0.205	0.270

(continued overleaf)









Sprinkler Systems Installation Guide

Applications and planning guidelines

Table 7: Continued

Designation	Pressfitting	Loss Coefficient	Dimensions Ø x s (mm)			
			12 x 1.0	15 x 1.0	18 x 1.0	22 x 1.0
T-piece (through-flow for flow separation)		0.2	0.076	0.106	0.137	0.180
T-piece (counterflow for flow integration)		3.0	1.145	1.587	2.052	2.702
T-piece (counterflow for flow separation)		1.5	0.572	0.793	1.026	1.351
Cross-piece 30° (through-flow)		0.2	—	—	0.137	0.180
Pipe cross 30° (flow separation)		1.3	—	—	0.889	1.171
Pipe cross 30° (flow integration)		0.9	—	—	0.616	0.811
Pipe cross 90° (through-flow)		0.2	—	0.106	0.137	0.180
Pipe cross 90° (flow separation)		1.7	—	0.899	1.163	1.531
Pipe cross 90° (flow integration)		1.3	—	0.688	0.889	1.171

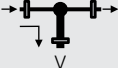
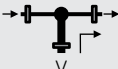
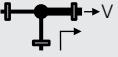

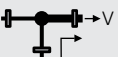
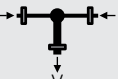



Table 8: Equivalent pipe length – Mapress Ø 28 - 54mm

Designation	Pressfitting	Loss Coefficient	Dimensions Ø x s (mm)			
			28 x 1.5	35 x 1.5	42 x 1.5	54 x 1.5
Bend 90°		0.7	0.829	1.121	1.427	1.975
Elbow adaptor 90°		1.5	1.777	2.403	3.057	4.232
Pipe bridge		0.5	0.592	—	—	—
Bend 45°		0.5	0.592	0.801	1.019	1.411
Reducer		0.2	0.237	0.320	0.408	0.564
Sleeve/Adaptor		0.1	0.118	0.160	0.204	0.282
T-piece (flow separation)		1.3	1.540	2.082	2.649	3.668
T-piece (flow integration)		0.9	1.066	1.442	1.834	2.539
T-piece (through-flow for flow integration)		0.3	0.355	0.481	0.611	0.846
T-piece (through-flow for flow separation)		0.2	0.237	0.320	0.408	0.564
T-piece (counterflow for flow integration)		3.0	3.553	4.805	6.114	8.465
T-piece (counterflow for flow separation)		1.5	1.777	2.403	3.057	4.232

Sprinkler Systems Installation Guide

Applications and planning guidelines

Table 9: Equivalent pipe length – Mapress Ø 66.7 - 108mm

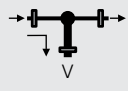
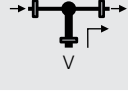
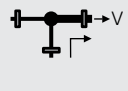
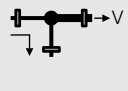
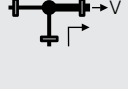
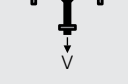
Designation	Pressfitting	Loss Coefficient	Dimensions Ø x s (mm)			
			66.7 x 1.2	76.1 x 2.0	88.9 x 2.0	108 x 2.5
Bend 90°		0.7	2.620	3.008	3.660	4.614
Elbow adaptor 90°		1.5	5.615	6.445	7.843	9.886
Pipe bridge		0.5	—	—	—	—
Bend 45°		0.5	1.872	2.148	2.614	3.295
Reducer		0.2	0.749	0.859	1.046	1.318
Sleeve/Adaptor		0.1	0.374	0.430	0.523	0.659
T-piece (flow separation)		1.3	4.866	5.586	6.797	8.568
T-piece (flow integration)		0.9	3.369	3.867	4.706	5.932
T-piece (through-flow for flow integration)		0.3	1.123	1.289	1.569	1.977
T-piece (through-flow for flow separation)		0.2	0.749	0.859	1.046	1.318
T-piece (counterflow for flow integration)		3.0	5.615	6.445	7.843	9.886
T-piece (counterflow for flow separation)		1.5	11.230	12.890	15.686	19.772

3.7 Expansion compensation

Pipes expand differently due to thermal effects depending on the product material. This should be considered when:

- Creating expansion space
- Installing expansion compensations
- Positioning fixed points and sliding points

The bending and torsional stress occurring during the operation of a pipe are reliably absorbed, taking the expansion compensation into account.

The following affect the expansion compensation:

- Material
- Building conditions
- Operating conditions.

Slight changes in the length of pipes can be accommodated by the elasticity of the pipe network.

Expansion compensators used are:

- Pipe leg
- U bend.

The following show the principle assembly of the pipe leg and U bend.

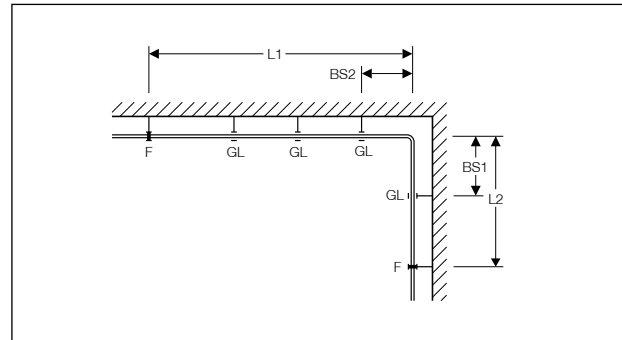

Figure 4: Expansion compensation by pipe leg

BS: Bending leg
 F: Fixed point
 GL: Sliding point
 L: Pipe length

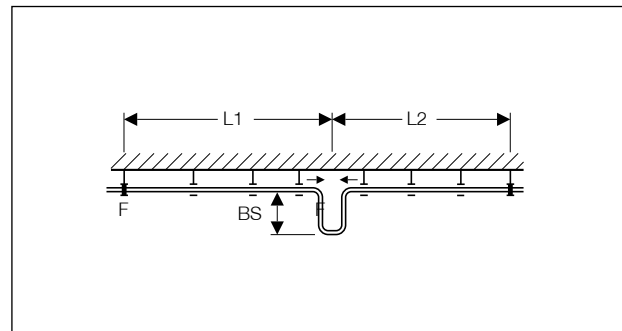

Figure 5: Expansion compensation by U bends

BS: Bending leg
 F: Fixed point
 L: Pipe length

3.7.1 Calculating expansion in Mapress Stainless Steel

The expansion of pipes also depends on the type of product material. Material dependent settings must be considered when calculating the length of the bending leg. The following table lists the parameters for Mapress Stainless Steel.

Table 10: Material dependent parameters for calculating the bending leg length of Mapress Stainless Steel

Material of pipe	System pipe	Coefficient of thermal expansion α (mm/m·K)	Material Constant	
			C	U
Cr-Ni-Mo steel material no. 1.4401 (BS 316)	Mapress Stainless Steel	0.0165	60	34

The calculation of the bending leg length comprises of the following steps:

- Calculation of the change in length Δl
- Calculation of the bending leg length.

The following section shows example values for calculating the bending leg length L_B and L_U for Mapress Stainless Steel.

Calculation of the change in length Δl

The change in length is determined with the following formula:

$$\Delta l = L \cdot \alpha \cdot \Delta T$$

Δl : Change in length [m]

L: Pipe length [m]

ΔT : Temperature differential (operating temperature – ambient temperature at time of installation) [K]

A: Coefficient of thermal expansion mm/[m·K]

Given:

- Material: Cr-Ni-Mo steel material no. 1.4401 (BS 316)
- $\alpha = 0.0165$ mm/[m·K]
- L = 5 [m]
- $\Delta T = 50$ [K]

Required:

- Change in length Δl of the pipe (mm).

Solution:

$$\Delta l = L \cdot \alpha \cdot \Delta T \quad \left[\frac{\text{m} \cdot \text{mm} \cdot \text{K}}{\text{m} \cdot \text{K}} = \text{m} \right]$$

$$\Delta l = 5\text{m} \cdot 0.0165 \frac{\text{mm}}{(\text{m} \cdot \text{K})} \cdot 50\text{K}$$

$$\Delta l = 4.1\text{mm}$$

Table 11: Change in length Δl (mm) for Mapress Stainless Steel system pipe

Pipe length L (m)	Temperature differential ΔT (K)									
	10	20	30	40	50	60	70	80	90	100
1	0.17	0.33	0.50	0.66	0.83	0.99	1.16	1.32	1.49	1.65
2	0.33	0.66	0.99	1.32	1.65	1.98	2.31	2.64	2.97	3.30
3	0.50	0.99	1.49	1.98	2.48	2.97	3.47	3.96	4.46	4.95
4	0.66	1.32	1.98	2.64	3.30	3.96	4.62	5.28	5.94	6.60
5	0.83	1.65	2.48	3.30	4.13	4.95	5.78	6.60	7.43	8.25
6	0.99	1.98	2.97	3.96	4.95	5.94	6.93	7.92	8.91	9.90
7	1.16	2.31	3.47	4.62	5.78	6.93	8.09	9.24	10.40	11.55
8	1.32	2.64	3.96	5.28	6.60	7.92	9.24	10.56	11.88	13.20
9	1.49	2.97	4.46	5.94	7.43	8.91	10.40	11.88	13.37	14.85
10	1.65	3.30	4.95	6.60	8.25	9.90	11.55	13.20	14.85	16.50

Calculation of the bending leg length: Stainless Steel

The calculation of the bending leg length depends on the type of bending leg:

- Expansion compensation through pipe leg / for branch pipe: Calculation of the bending leg length L_B
- Expansion compensation by U bends: Calculation of the bending leg length L_U

Calculation of the bending leg length L_B

The bending leg length L_W to be calculated is defined as follows with expansion compensation through pipe legs and for branch pipes:

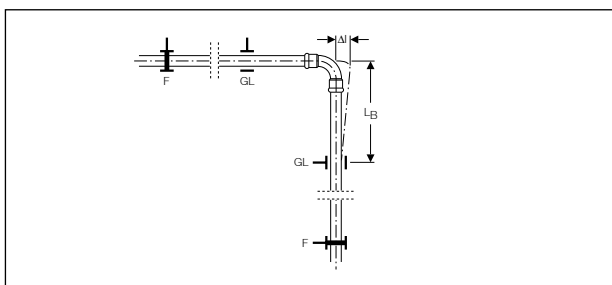

Figure 6: Expansion compensation by pipe leg

- F: Fixed point
- GL: Sliding point
- L_B : Length of the bending leg

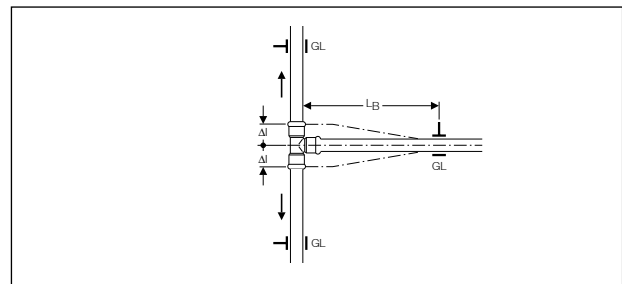

Figure 7: Expansion compensation for branching pipe

- F: Fixed point
- GL: Sliding point
- L_B : Length of the bending leg

Sprinkler Systems Installation Guide

Applications and planning guidelines

The bending leg length L_B is determined with the following formula:

$$L_B = C \cdot \sqrt{d \cdot \Delta l}$$

- L_B : Length of the bending leg [m]
- d : Outside pipe diameter [mm]
- Δl : Change in length [m]
- C : Material constant (refer to Table 10 "Material dependant parameters for calculating the bending leg length of Mapress Stainless Steel" on page 16).
- L : Pipe length [m]

Given:

- Material: Cr-Ni-Mo steel material no. 1.4401 (BS 316)
- $C = 60$
- $d = 54\text{mm}$
- $\Delta l = 0.030\text{m}$

Required:

- L_B (m)

Solution:

$$L_B = C \cdot \sqrt{d \cdot \Delta l} \quad [\sqrt{\text{m} \cdot \text{m}} = \text{m}]$$

$$L_B = 60 \cdot \sqrt{0.054 \cdot 0.030}$$

$$L_B = 2.41\text{m}$$

Calculation of the bending leg length L_U

The bending leg length L_U to be calculated is defined with the following formula:

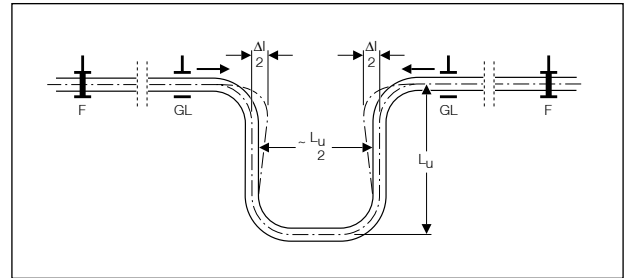

Figure 8: U bend expansion compensation from bent pipe

- F: Fixed point
- GL: Sliding point
- L_U : Length of the bending leg

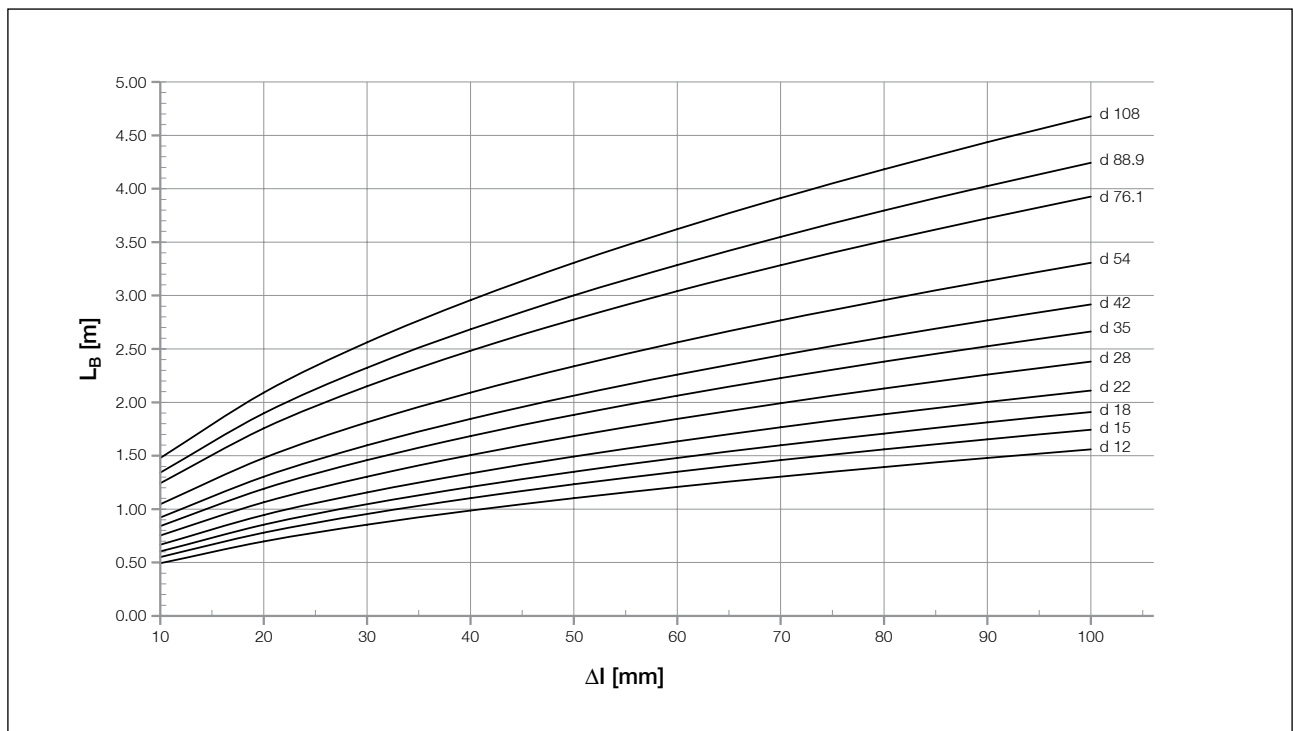

Figure 9: Determination of the bending leg length L_B for Mapress Stainless Steel

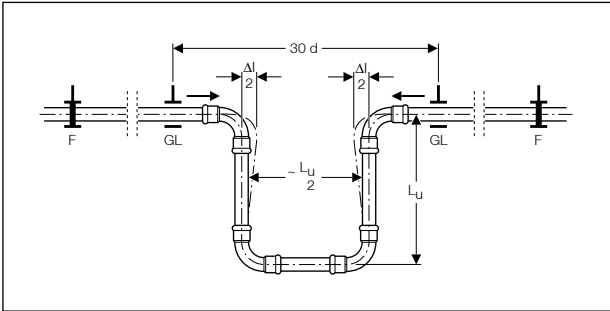

Figure 10: U bend expansion compensation with pressfittings

F: Fixed point

GL: Sliding point

L_U : Length of the bending leg

The bending leg L_U is determined with the following formula:

$$L_U = U \cdot \sqrt{d \cdot \Delta l}$$

L_U : Length of the bending leg [m]

D: Outside pipe diameter [mm]

Δl : Change in length [m]

U: Material constant (refer to Table 10 "Material dependant parameters for calculating the bending leg length of Mapress Stainless Steel" on page 16).

L: Pipe length [m]

Given:

- Material: Cr-Ni-Mo steel material no. 1.4401 (BS 316)
- $U = 34$
- $d = 54\text{mm}$
- $\Delta l = 0.030\text{m}$

Required:

- L_U [m]

Solution:

$$L_U = U \cdot \sqrt{d \cdot \Delta l} \quad [\sqrt{\text{m} \cdot \text{m}} = \text{m}]$$

$$L_U = 34 \cdot \sqrt{0.054 \cdot 0.030}$$

$$L_U = 1.37\text{m}$$

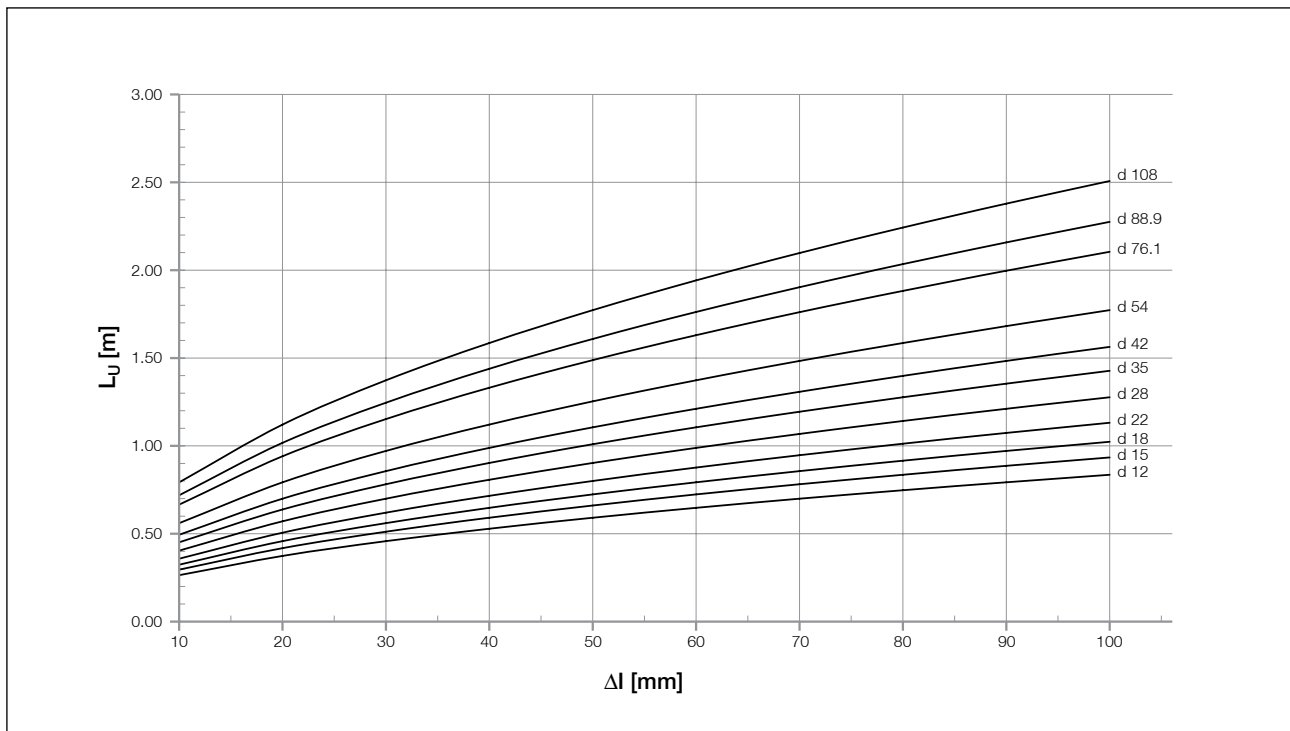

Figure 11: Determination of the bending leg length L_U for Mapress Stainless Steel

3.7.2 Calculating expansion in Mapress Carbon Steel

The expansion of pipes also depends, amongst others, on the type of product material. Material dependent parameters must be considered when calculating the length of the bending leg. The following table lists the parameters for Mapress Carbon Steel.

Table 12: Material dependent parameters for calculating the bending leg length of Mapress Carbon Steel

Material of pipe	System pipe	Coefficient of thermal expansion α (mm/m·K)	Material Constant	
			C	U
Non-alloy steel, material no. 1.0215	Mapress Carbon Steel	0.012	45	25

The calculation of the bending leg length comprises of the following steps:

- Calculation of the change in length Δl
- Calculation of the bending leg length L_B

The following section shows example values for calculating the bending leg length L_W and L_U for Mapress Carbon Steel.

Calculation of the change in length Δl

The change in length is determined with the following formula:

$$\Delta l = L \cdot \alpha \cdot \Delta T$$

- Δl : Change in length [m]
 L : Pipe length [m]
 ΔT : Temperature differential (operating temperature – ambient temperature at time of installation) [K]
 α : Coefficient of thermal expansion mm/[m·K]

Given:

- Material: Non-alloy steel material no. 1.0034
- $\alpha = 0.0120$ m/[m·K]
- $L = 35$ [m]
- $\Delta T = 50$ [K]

Required:

- Change in length Δl of the pipe [mm]

Solution:

$$\Delta l = L \cdot \alpha \cdot \Delta T \quad \left[\frac{\text{m} \cdot \text{mm} \cdot \text{K}}{\text{m} \cdot \text{K}} = \text{m} \right]$$

$$\Delta l = 35\text{m} \cdot 0.012 \frac{\text{mm}}{(\text{m} \cdot \text{K})} \cdot 50\text{K}$$

$$\Delta l = 21\text{mm}$$

Table 13: Change in length Δl (mm) for Mapress Carbon Steel system pipe

Pipe length L (m)	Temperature differential ΔT (K)									
	10	20	30	40	50	60	70	80	90	100
1	0.12	0.24	0.36	0.48	0.60	0.72	0.84	0.96	1.08	1.20
2	0.24	0.48	0.72	0.96	1.20	1.44	1.68	1.92	2.16	2.40
3	0.36	0.72	1.08	1.44	1.80	2.16	2.52	2.88	3.24	3.60
4	0.48	0.96	1.44	1.92	2.40	2.88	3.36	3.84	4.32	4.80
5	0.60	1.20	1.80	2.40	3.00	3.60	4.20	4.80	5.40	6.00
6	0.72	1.44	2.16	2.88	3.60	4.32	5.04	5.76	6.48	7.20
7	0.84	1.68	2.52	3.36	4.20	5.04	5.88	6.72	7.56	8.40
8	0.96	1.92	2.88	3.84	4.80	5.76	6.72	7.68	8.64	9.60
9	1.08	2.16	3.24	4.32	5.40	6.48	7.56	8.64	9.72	10.80
10	1.20	2.40	3.60	4.80	6.00	7.20	8.40	9.60	10.80	12.00

Calculation of the bending leg length: Carbon Steel

The calculation of the bending leg length depends on the type of bending leg:

- Expansion compensation through pipe leg / for branch pipe: Calculation of the bending leg length L_B
- Expansion compensation by U bends: Calculation of the bending leg length L_U

Calculation of the bending leg length L_B

The bending leg length L_B to be calculated is defined as follows with expansion compensation through pipe legs and for branch pipes:

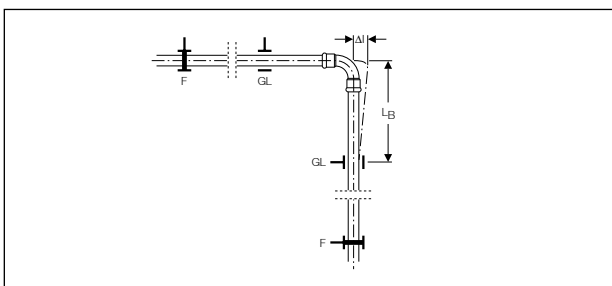

Figure 12: Expansion compensation by pipe leg

- F: Fixed point
- GL: Sliding point
- L_B : Length of the bending leg

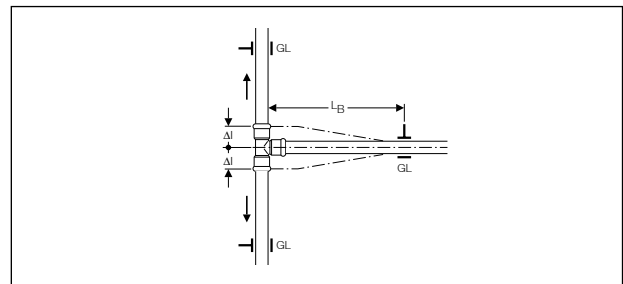

Figure 13: Expansion compensation for branching pipe

- F: Fixed point
- GL: Sliding point
- L_B : Length of the bending leg

Sprinkler Systems Installation Guide

Applications and planning guidelines

The bending leg length L_B is determined with the following formula:

$$L_B = C \cdot \sqrt{d \cdot \Delta l}$$

- L_B : Length of the bending leg [m]
- d : Outside pipe diameter [mm]
- Δl : Change in length [m]
- C : Material constant (refer to Table 12 "Material dependent parameters for calculating the bending leg length of Mapress Carbon Steel" on page 20).
- L : Pipe length [m]

Given:

- Material: Non-alloy steel material no. 1.0034
- $C = 45$
- $d = 54$ [mm]
- $\Delta l = 0.021$ [m]

Required:

- L_B [m]

Solution:

$$L_B = C \cdot \sqrt{d \cdot \Delta l} \quad [\sqrt{m \cdot m} = m]$$

$$L_B = 45 \cdot \sqrt{0.054 \cdot 0.021}$$

$$L_B = 1.52m$$

Calculation of the bending leg length L_U

The bending leg length L_U to be calculated is defined with the following formula:

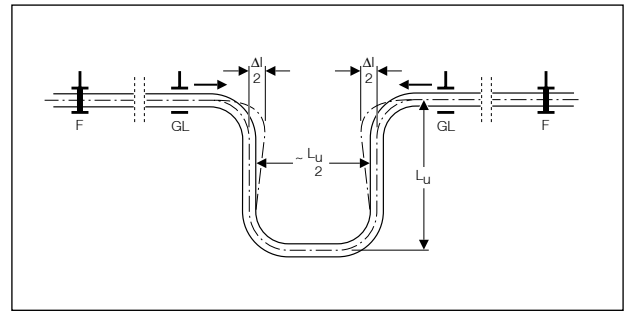

Figure 14: U bend expansion compensation from bent pipe

- F: Fixed point
- GL: Sliding point
- L_U : Length of the bending leg

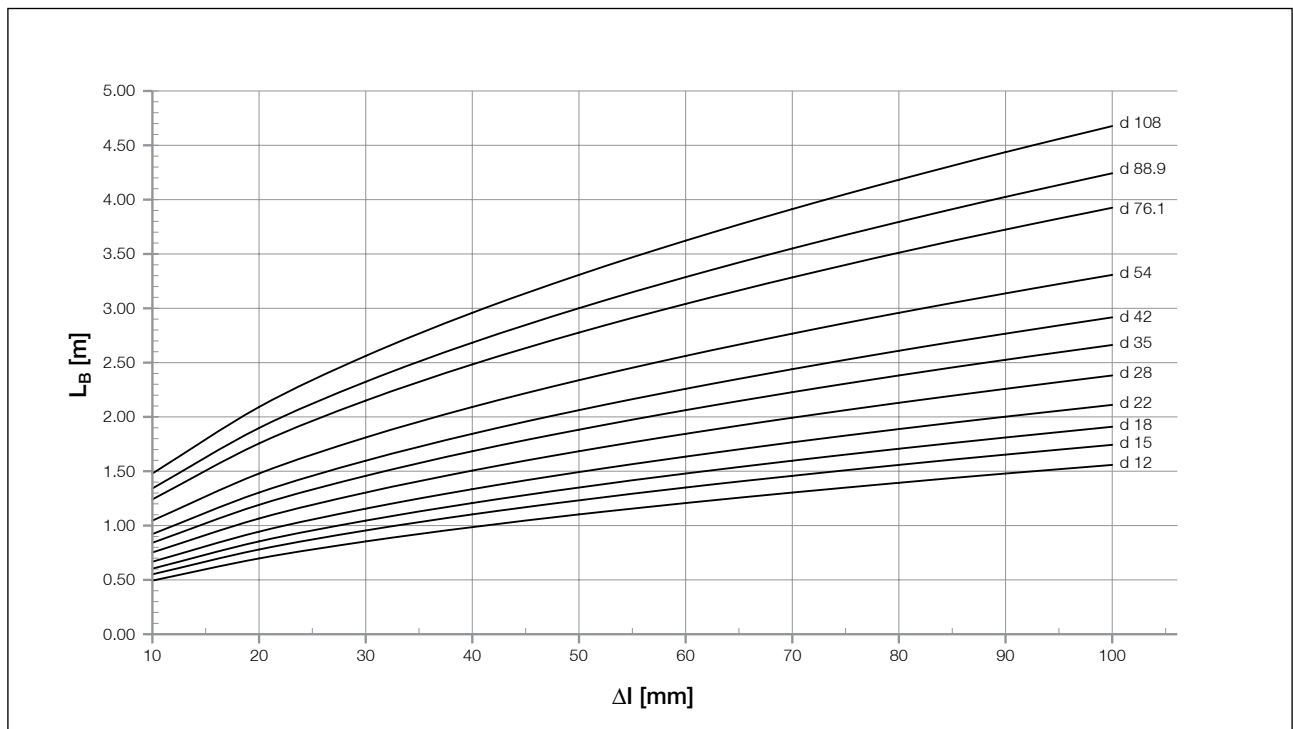

Figure 15: Determination of the bending leg length L_B for Mapress Carbon Steel

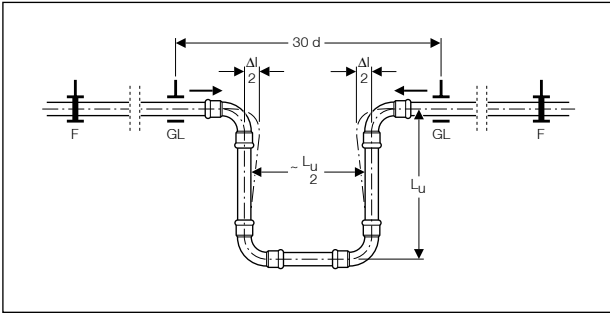

Figure 16: U bend expansion compensation with pressfittings

- F: Fixed point
 GL: Sliding point
 L_U : Length of the bending leg

The bending leg L_U is determined with the following formula:

$$L_U = U \cdot \sqrt{d \cdot \Delta l}$$

- L_U : Length of the bending leg (m)
 D: Outside pipe diameter (mm)
 Δl : Change in length (m)
 U: Material constant (refer to Table 12 "Material dependant parameters for calculating the bending leg length of Mapress Carbon Steel" on page 20).
 L: Pipe length (m)

Given:

- Material: Non-alloy steel material no. 1.0034
- $U = 25$
- $d = 54\text{mm}$
- $\Delta l = 0.021\text{m}$

Required:

- L_U (m)

Solution:

$$L_U = U \cdot \sqrt{d \cdot \Delta l} \quad [\sqrt{\text{m} \cdot \text{m}} = \text{m}]$$

$$L_U = 25 \cdot \sqrt{0.054 \cdot 0.021}$$

$$L_U = 0.84\text{m}$$

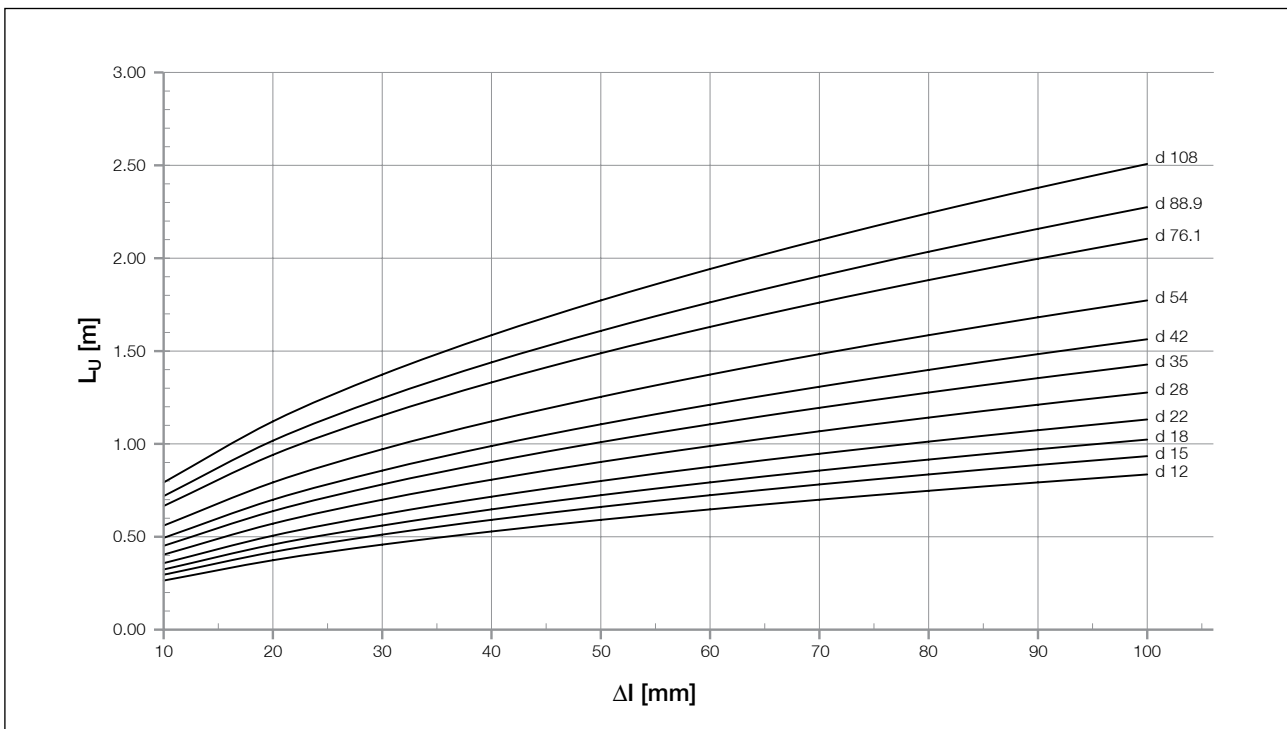

Figure 17: Determination of the bending leg length L_U for Mapress Carbon Steel

3.8 Laying techniques

There are different types of pipe laying:

- On the wall
- In installation ducts
- Concealed
- Under cast floors
- In the ground
- In ceilings

There is room for expansion on the wall or in installation ducts. When pipes are concealed it must be ensured that they are surrounded by an elastic padding layer of fibre insulation material, such as glass wool or rock wool, or in closed-cell foam. This also meets acoustic insulation requirements.

Pipes installed under cast floors shall be fitted in the impact insulation layer and can expand freely. The vertical pipe exits from the floor should be paid particular attention. Branches in the area of the screeded floor must be fitted with an elastic sleeve. The same applies for pipe openings in walls and ceilings, where padding ensures freedom of movement in all directions.

The padding and/or elastic sleeve should have the same fire resistance as the void through which it is passing in order to prevent a potential fire from spreading.

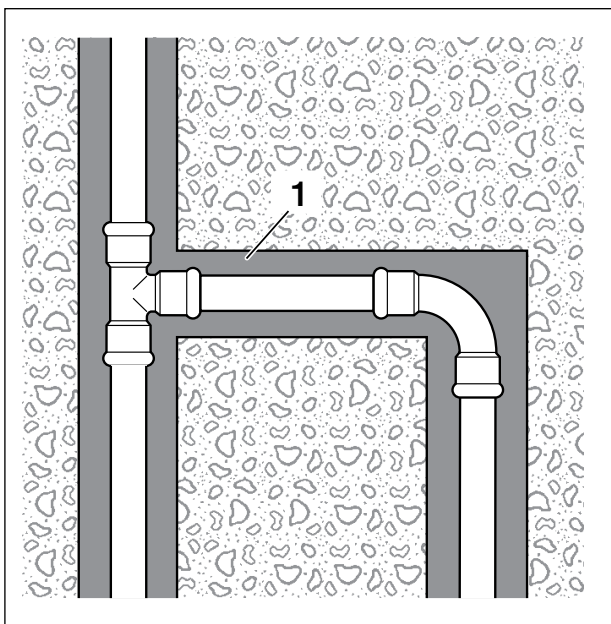

Figure 18: Concealed pipe

- 1 Elastic padding

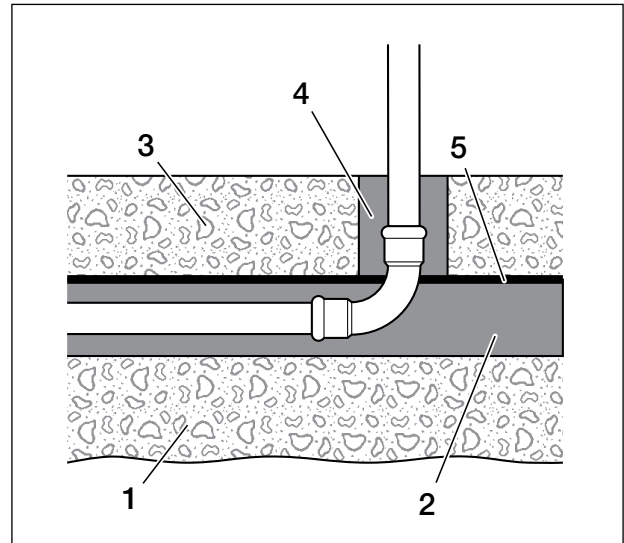

Figure 19: Pipe under cast plaster floor

- 1 Solid ceiling
- 2 Insulation layer
- 3 Cast floor
- 4 Elastic sleeve
- 5 Cover

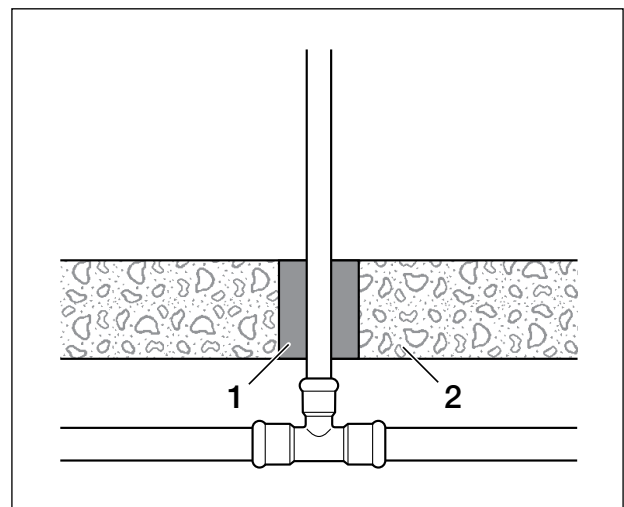

Figure 20: Pipe under ceiling openings

- 1 Elastic padding
- 2 Ceiling

3.9 Wall penetrations

Where it is necessary for the product to pass through a fire rated wall, partition or other divider it is essential that fire stopping of the fire rated wall, partition or other divider is preserved. Use an appropriate fire stopping product at the penetration if necessary.

4 Installation

4.1 Tooling

The following tooling combinations should be used for installing Geberit Mapress for fire protection systems.

Table 14: Suitable tooling combinations for Geberit Mapress and Fire Protection systems

Diameters Pressed	Model	Voltage	Plug type	Article No.	Jaws type compatability	Pressing Jaw (Size mm)	Adaptor	Pressing Collar (Size mm)
22-88.9mm	ECO 301	115V / 50Hz	CEE 17 yellow	691.312.1P.3	3	90644 (22mm)	35/42/54mm = (ZB302) 90668	35mm=90538 42mm=90539
	ECO 301	230V / 50Hz	BS 1363 A plug	691.310.P5.3	3		90645 (28mm)	76.1 / 88.9mm = (ZB321) 90674
	ECO 301	125v / 60Hz	Marine NEMA plug	691.312.2P.3	3			
76-108mm	HCPS	230V / 50Hz	BS 1363 A plug	691.420.P5.1	HCPS	n/a	n/a	76.1mm=90570
	HCPS	115V / 50Hz	CEE 17 yellow	691.422.1P.1				88.9mm=90571
								108mm=90572

4.2 Transport and storage

Do not allow Geberit Mapress system pipes and pressfittings to get dirty or damaged in transit or storage. Pipes need to be stored inside in a dry location.



Only shorten the fittings with plain ends up to the maximum permissible shortening dimension k, indicated in the product guide.



WARNING
Risk of corrosion

- ▶ Keep cutting tools and deburring tools free from Carbon Steel chips when cutting Mapress Stainless Steel
- ▶ Do not use high-speed cutting wheels to cut the pipe or fittings to length
- ▶ Only use cutting tools that are suitable for working with steel

Leaking press connection can be caused by damaged seal ring

- ▶ Deburr the outside and inside of the pipe ends completely
- ▶ Do not tilt the pipe into the pressfitting.
- ▶ Push the pressfitting onto the pipe, turning the pipe slightly
- ▶ Only use lubricants which are free from oil and grease

4.3 Making a Mapress press connection

A Mapress press connection is made as follows:

- Prepare the pipe and fitting for the pressing operation.
- Push pipe into fitting to correct insertion depth.
- Optional: With Ø 54 - 108mm fit the mounting device MH 1.
- Press the fitting.

4.4 Prepare the pipe and fitting for the pressing operation

- 1 Check that the pipe and fitting are clean, undamaged and free from scoring or dents.
- 2 Determine the pipe length.
- 3 Cut the pipe to the correct length.

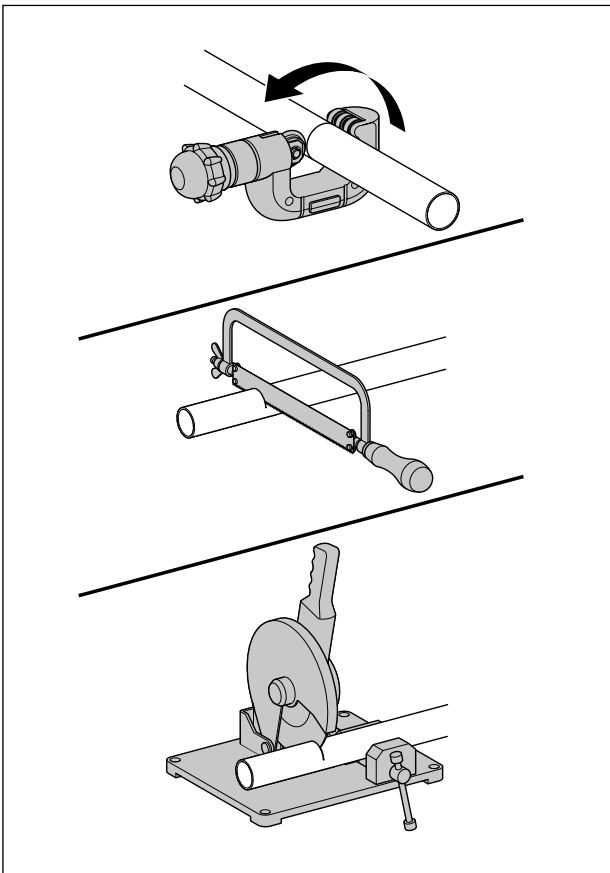

- 4 Deburr the pipe ends, internally and externally.

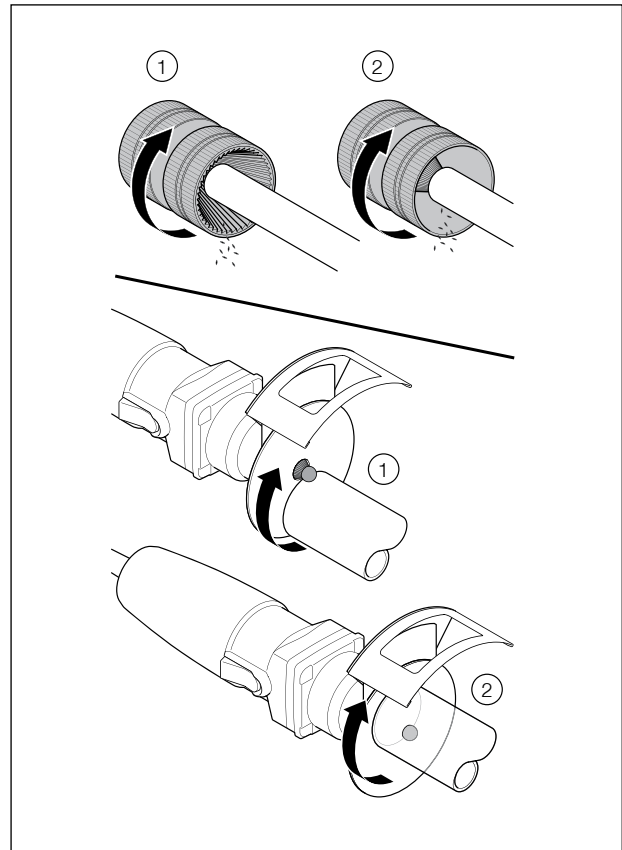

- 5 Clean chips from the pipe ends.

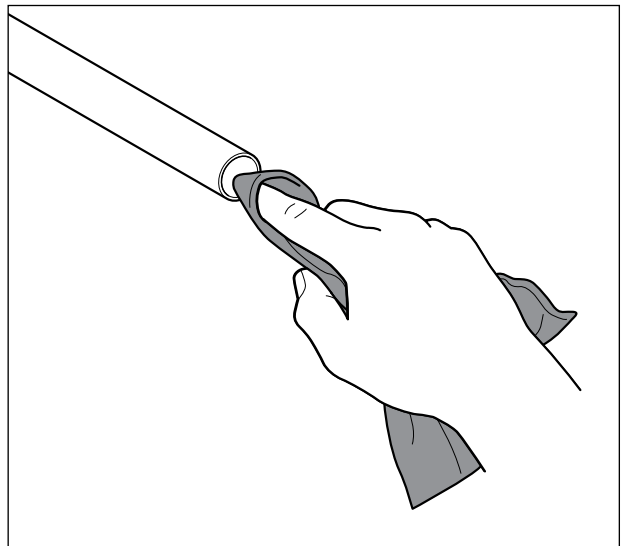

6a Mark the insertion distance.

i Insufficient mechanical strength if correct insertion (E) is not observed.

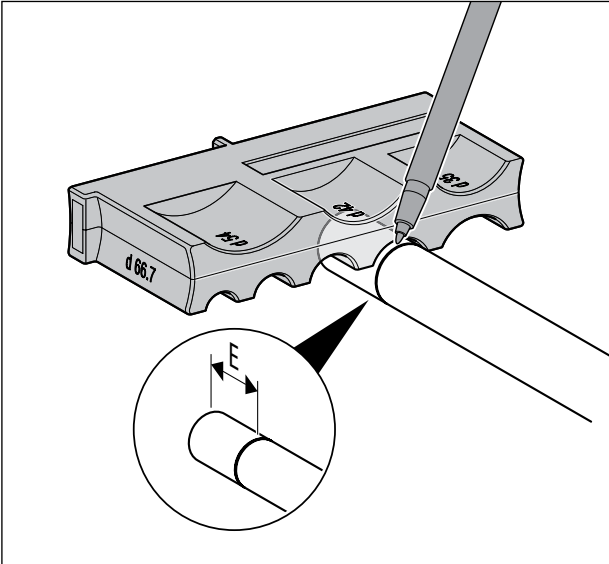

6b On fittings with a plain end, mark the insertion distance on the end.

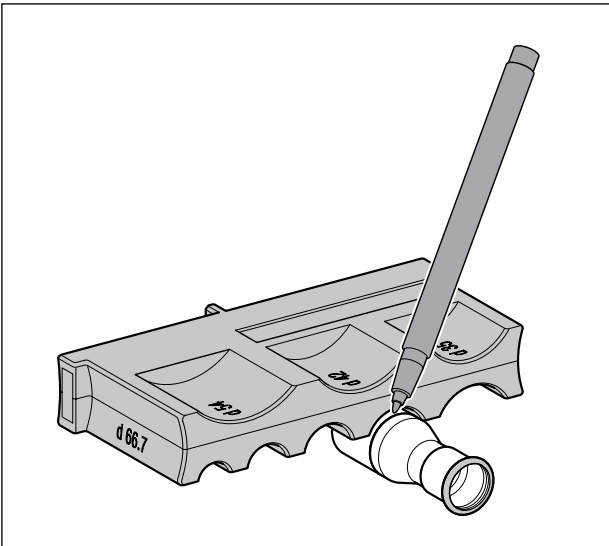

7 Remove the plug from the fitting.

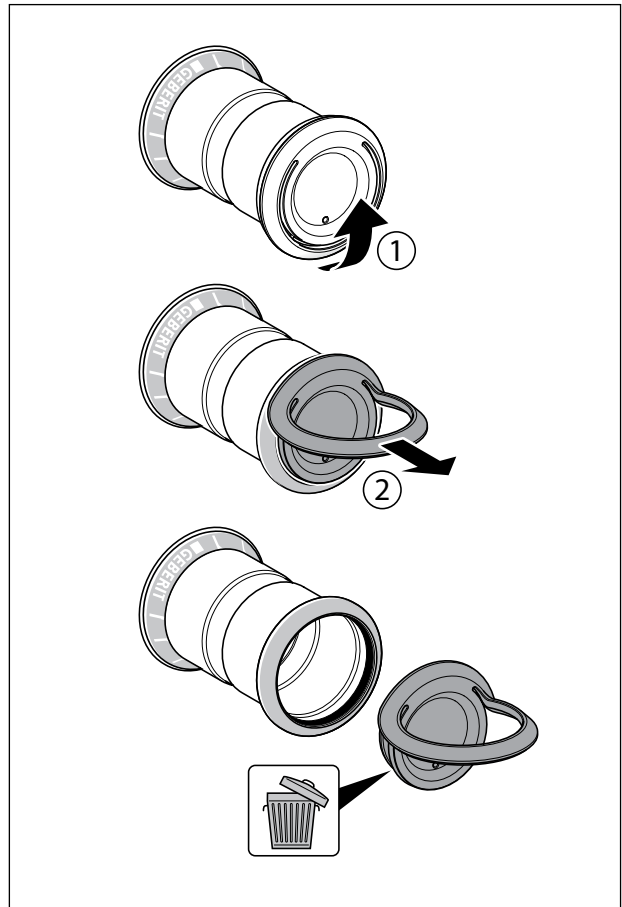

8 Check the seal ring.

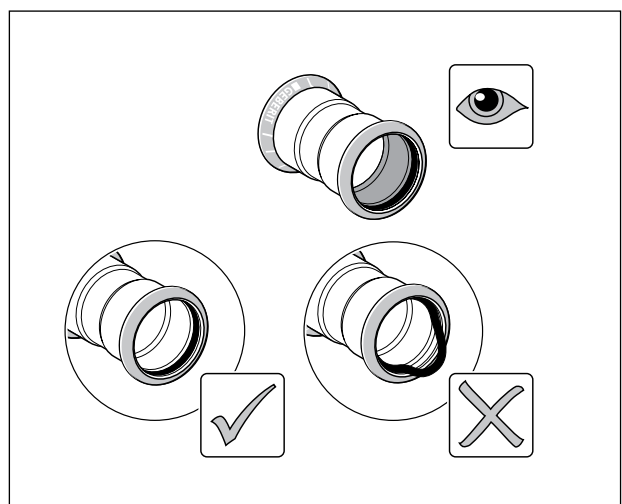

Sprinkler Systems Installation Guide

Installation

- 9 Push the fitting onto the pipe up to the marked insertion distance.

i The fitting can be pushed in more easily if oil and grease-free lubricant is applied or the fitting is immersed in water or soapy water.

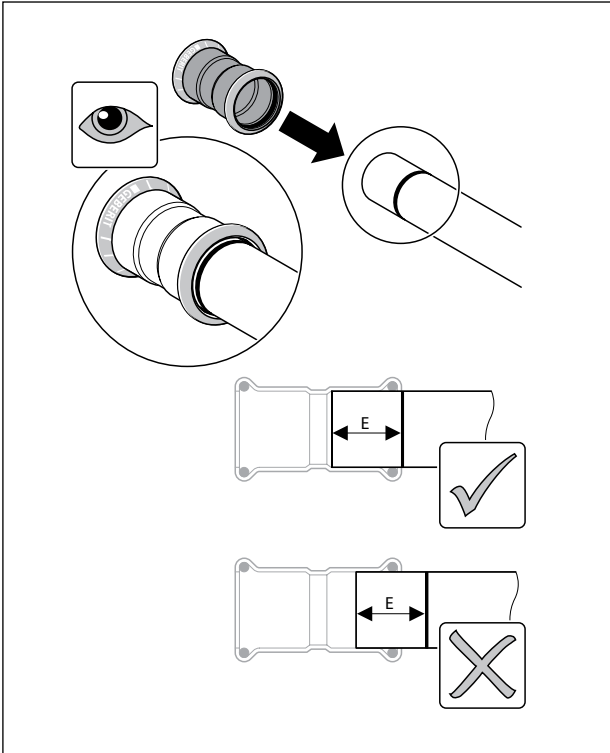

- 10 Align the pipe.

Make the connection with the threaded fitting

- 1 Fix the pipe in position.
- 2 Seal in the threaded connection.
- 3 Insert the threaded fitting and screw into place, counter holding the threaded fitting.



CAUTION
Leaking connection due to stress corrosion cracking. Do not use Teflon for sealing

Optional: with Ø 54 - 108mm fit the mounting aid MH 1

i The installation dimensions are given in the operating instructions of the mounting aid.

- Clamp the pipes with the jaws of the mounting aid.

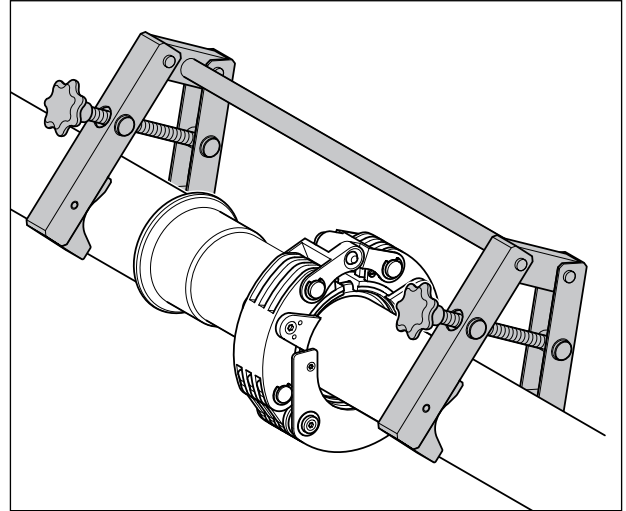

Press the fitting

Prerequisites

- The pipe or pre-assembled elements are aligned
- Threaded joints must be sealed in.

- 1 Ensure that the diameter of the pressfitting matches the diameter of the pressing jaw or pressing collar: Ø 12 - 35mm use pressing jaw, Ø 42 - 108mm use pressing collar and adaptor.
- 2 Press the fitting.

Result

- The mark of the insertion distance is visible.

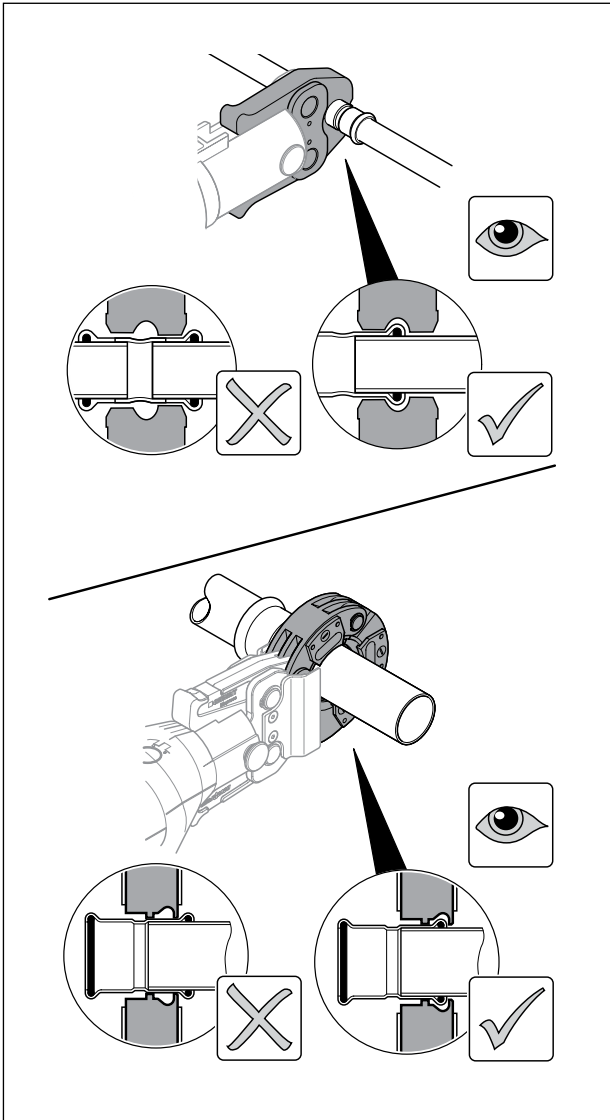

5 Commissioning

5.1 Bending the system pipes

Geberit Mapress system pipes can be cold bent. To do so, use commercially available bending tools (manually, hydraulically or electrically operated). It is important to always use the bending segments for the particular outer diameter of the system pipes. The bending radius and the suitability of the bending tool is determined by the manufacturer of the tool. Geberit Mapress recommends using a bending radius of $r = 3.5 \times OD$.

5.2 Connections

- **Connecting to sprinkler heads and ISO 65 pipework**

In order to connect Geberit Mapress to alternative piping systems, accessories and sprinkler heads, threaded adaptors are available under the LPCB listing of approved products.

- **Threaded joints**

Geberit Mapress components can be combined with threaded fittings or system pipes made of non-ferrous metal. When Geberit Mapress Stainless Steel adaptors are used, only chloride-free sealants may be employed.

- **Flange connections**

Geberit Mapress components can be connected to DIN flanges [PN 10/16] with flanged adaptors (see Geberit Supply Systems Product Guide)

5.3 Flushing the pipes

All metallic piping systems are at a high risk of corrosion when they are partially filled. We recommend that the pipe is flushed thoroughly prior to commissioning using drinking water.

If the pipe cannot be completely drained before commissioning and if the pipe cannot be blown dry with air after flushing, the pipe must be flushed with fully desalinated water.

5.4 Pressure and leak test

All installation pipework shall be hydrostatically tested for no less than 2 hours, to a pressure of no less than 15 bar, or 1.5 times the maximum pressure to which the system will be subjected, (both measured at the installation control valves), whichever is the greater.

An initial test with air can be performed if there is to be a gap between the testing and commissioning phase.

For safety reasons, the pressure for this test should never exceed 3 bar. A second test with water should always be carried out immediately prior to commissioning.

5.5 Refilling and air-bleeding of the pipe system for commissioning

If the pipe system was drained completely after pressure testing, the water-carrying pipes must be thoroughly air-bled before commissioning and then remain completely full. The water used to fill the pipes must comply with the drinking water directive 2001, with regard to its chloride content.

5.6 Compatibility of additives

Water additives are mainly used for providing anti-freeze properties for wet sprinkler systems during the winter season. Commonly used are mixtures based on anti-freeze agents (ethylene- or propylene glycol) in combination with corrosion inhibitors. The glycols will always have an influence on the zinc layer on the inside of the piping system and can therefore not be recommended for use in conjunction with Geberit Mapress Carbon Steel internally/externally galvanised pipe.

Geberit Mapress is suitable for trace heating in areas where low temperatures can't be avoided

For a full list of compatible additives for use with Geberit Mapress Stainless Steel please see Tables 15 & 16.

Table 15: Suitable antifreeze agents for Geberit Mapress Stainless Steel

Additive	Test Conditions	Manufacturer ¹
	Concentration (%)	
Ethylene glycol (antifreeze basis)	Concentration for use, see manufacturer's information	Various manufacturers
Propylene glycol (antifreeze basis)	Concentration for use, see manufacturer's information	Various manufacturers

Table 16: Tested and approved corrosion protection agents for Geberit Mapress Stainless Steel

Additive	Test Conditions		Manufacturer ¹
	Concentration (%)	Temperature (°C)	
Castrol Zwipro III	100	20	Castrol
Diagloss CW 4001	3.5	40	Schweitzer Chemie, Freiberg/N.
DEWT-NC	0.4	20	Drew Ameroid, Hamburg
Hydrazine	Concentration for use, see manufacturer's information		Lanxess, Leverkusen
Levoxin 64	100	120	Lanxess, Leverkusen
Hygel H 140	100	20	Hydrogel Chemie, Werl
Kebocor 213	0.5	20	Kebo Chemie, Düsseldorf
Nalco 77382	0.5	20	Nalco Deutschland GmbH
Sodium diethyldithiocarbamate	0.07	20	Various manufacturers
Sodium sulphite	Concentration for use, see manufacturer's information		Various manufacturers
P3-ferrolix 332	0.5	20	Henkel AG, Düsseldorf
ST-DOS K-375	0.5	20	Schweitzer Chemie, Freiberg/N.
Thermodus JTH-L	1	90	Judo, Waiblingen
Tri-sodium phosphate	Concentration for use, see manufacturer's information		Various manufacturers
Varidos SIS	100	20	Schilling Chemie, Freiberg

Approval must be obtained from Geberit for non-listed agents. The manufacturer's instructions for use must also be observed.

5.7 Compatible paints and coatings

Primers and paints can be applied on Mapress Carbon Steel and Mapress Stainless Steel systems. From long term experience we can confirm that the primers and paints will have no negative effect on the seal rings in the pressfittings.

5.8 Maintenance

A sprinkler system should be regularly serviced, maintained and periodically inspected so that it will work properly in the event of a fire. Sprinkler systems have an extensive service, maintenance and inspection programme covering the whole

of their design life, including weekly, monthly, quarterly, yearly, three-yearly, up to ten-yearly checks and tests. Regular service and maintenance should be carried out in accordance with the LPC Rules (BS EN 12845 annex K) and Technical Bulletin TB 203, by a LPCB certified sprinkler contractor, for all but the monthly and weekly checks.

5.9 Service life

An expected service life in excess of 30 years can be achieved.

6 Support services

Geberit not only focuses on reliable and innovative products but on the services that accompany them. Whilst we hope this guide provides you with everything you need to install a Geberit fire protection system, further assistance is available as outlined below. Further literature is also available, including the Geberit Supply Systems Product Guide and Supply Systems Installation guide, by calling our literature line on 0800 007 5133 or by downloading from our website at www.geberit.co.uk

6.1 Geberit technical service

Our team of dedicated technical experts and sales managers are on hand to support both at the design stage and on-site. Please contact the Geberit technical team for assistance.

Geberit Sales Ltd,
Geberit House,
Academy Drive,
Warwick,
Warwickshire,
CV34 6QZ.

Freephone: 0800 077 8365
Fax: 0844 800 6604
Eire: +44 (0) 1926 516800

6.2 Training

Geberit provide full product training, either on-site or at the Geberit Academy at our headquarters in Warwick. Please contact your local sales manager for more details.